



REFRIGERATION

SERVING THE FOOD INDUSTRY SINCE 1951

49-INCH GLASS DOOR FREEZERS WITH 2 DOORS

Item #: 24273 Model: FR-CN-1250-D | Item #: 38025 Model: FR-CN-1250-C

HIGH PERFORMANCE AND QUALITY COMMERCIAL FREEZER

These glass door units feature self closing glass doors and high density polyurethane insulation.

Features:

- Outside material: Painted steel
- Self-closing doors
- Removable door gasket
- Plastic coated steel shelves with shelf tag holder
- Automatic defrosting
- European controller and compressor
- Polyurethane insulation



LIMITED WARRANTY
1 YEAR PARTS AND LABOR
5 YEARS PARTS ON COMPRESSOR

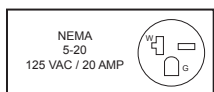

Authorized Dealer

REFRIGERATION

49-INCH GLASS DOOR FREEZERS WITH 2 DOORS



TECHNICAL DRAWING / DIMENSIONS

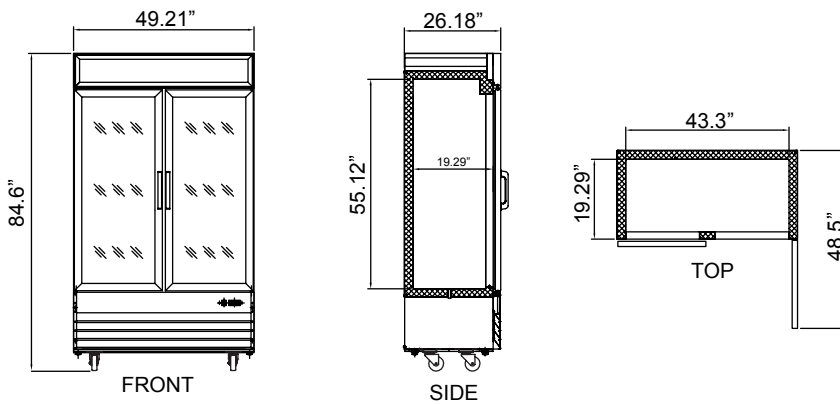

TECHNICAL SPECIFICATION

ITEM NUMBER	*24273	**38025
MODEL	FR-CN-1250-D	FR-CN-1250-C
DESCRIPTION	2-Door Glass Freezer	
TEMPERATURE RANGE	-22°C - -18°C / -7.6°F - -0.4°F	
MAX AMBIENT TEMP. RATING	32°C / 90°F	
POWER	1.58 HP / 1.17 kW	
ELECTRICAL	110 V / 60 Hz / 1 Ph	
AMPS	12	
REFRIGERANT	R404a	
ISOLATION MATERIAL	R141b	
COOLING SYSTEM	Ventilated	
NUMBER OF DOORS	2	
NUMBER OF SHELVES	8	
SHELF CAPACITY	90 lbs. / 41 kg.	
EXTERIOR DIMENSIONS (WDH)	49.21" x 26.18" x 84.6" / 1250 x 665 x 2149 mm	
INTERIOR DIMENSIONS (WDH)	43.3" x 19.29" x 55.12" / 1100 x 490 x 1400 mm	
PACKAGING DIMENSIONS	52.16" x 30.31" x 87" / 1325 x 770 x 2210 mm	
NET WEIGHT	397 lbs. / 180 kg.	
GROSS WEIGHT	452 lbs. / 205 kg.	

*requires a 20-amp "D" type breaker

**installed with a crankcase pressure regulator

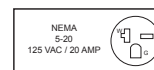

OMCAN INC.

Telephone: 1-800-465-0234

Fax: (905) 607-0234

Email: sales@omcan.com

Website: www.omcan.com



Follow us to keep up to date with the latest news and offers



2015.E.O.E